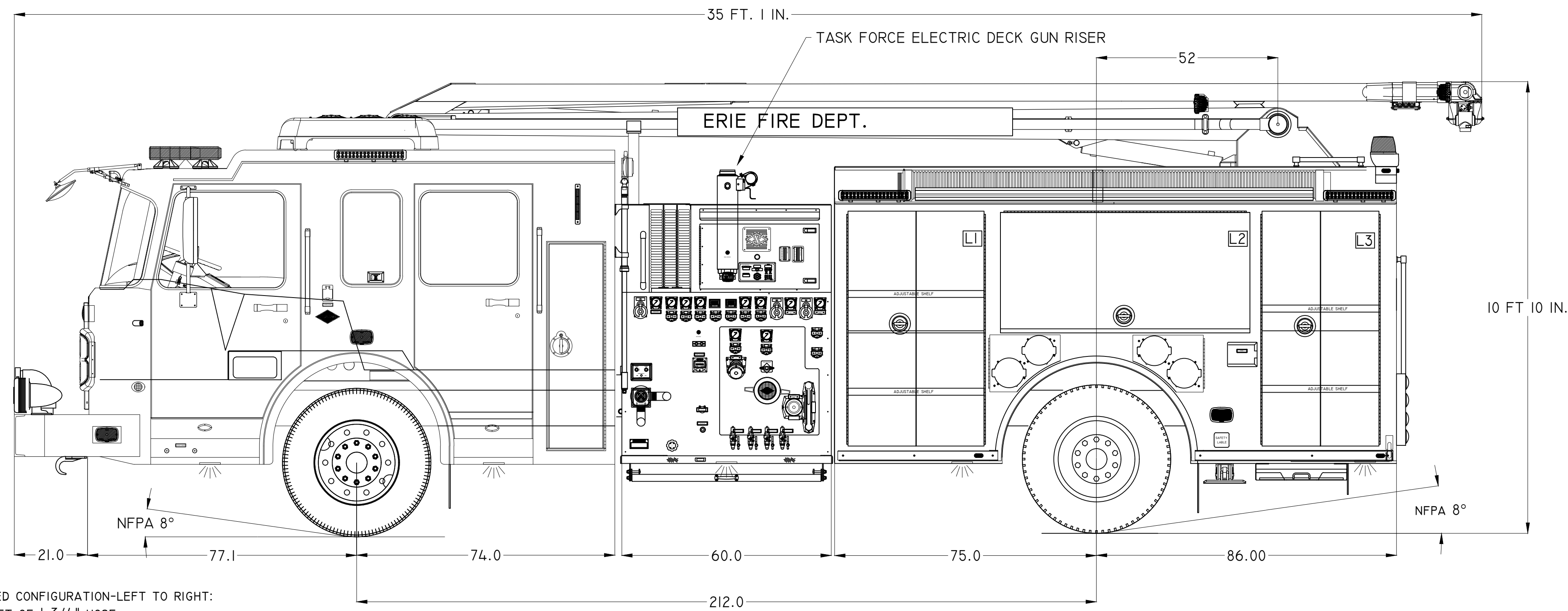
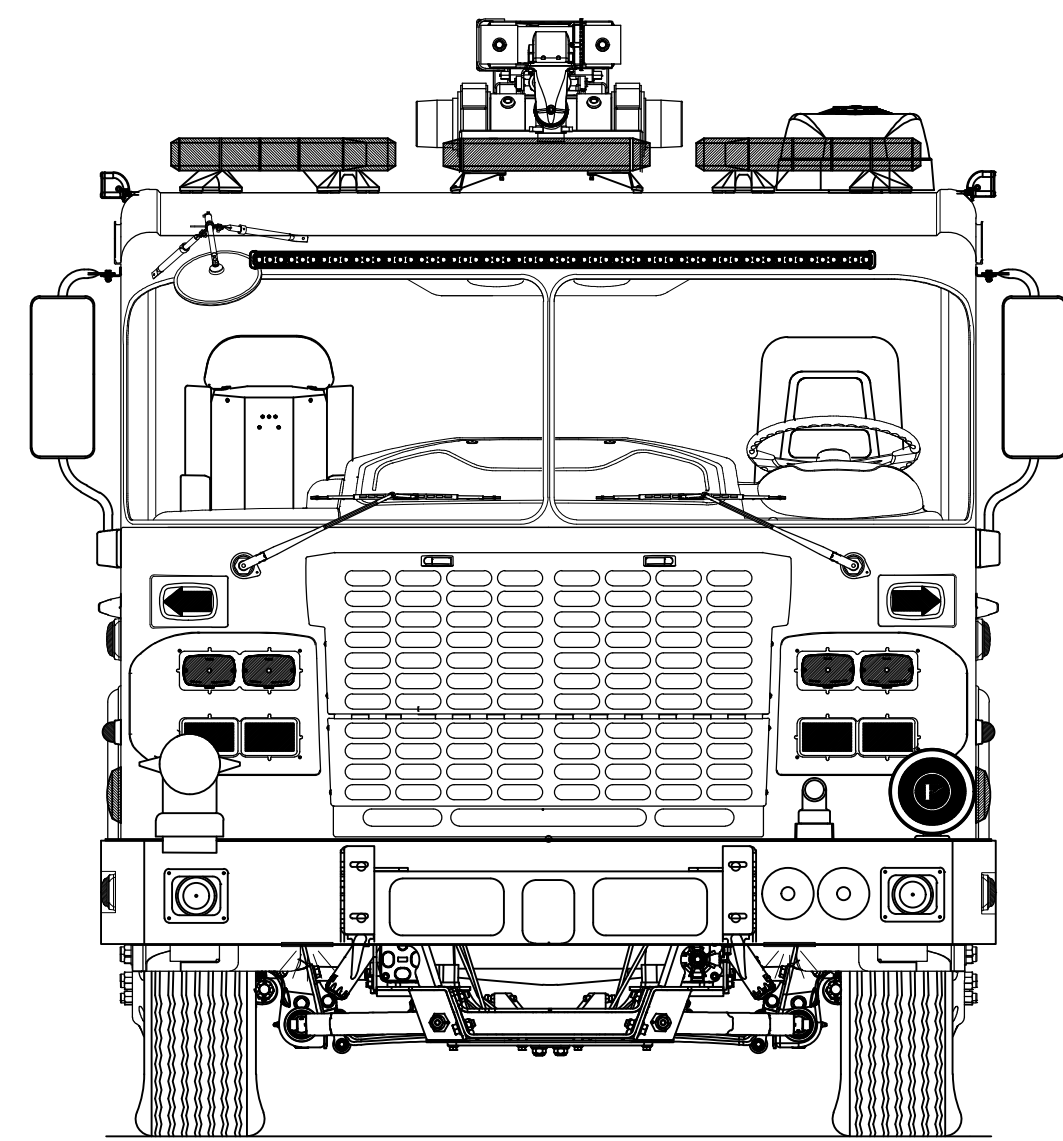
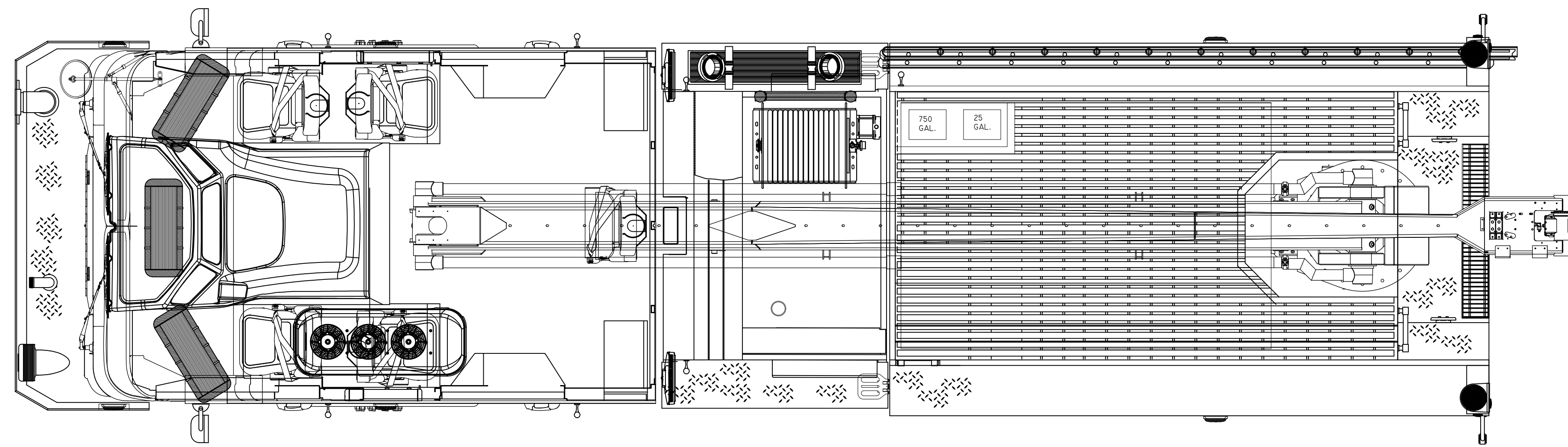

SPARTAN FIRE, LLC.
 EPHRATA, PA 17522

| | |
|---------------|--|
| CHASSIS: | SPARTAN GLADIATOR ELFD 5-IN. RAISED ROOF |
| ENGINE: | CUMMINS X-12 500 HP |
| TRANSMISSION: | ALLISON 4500 EVS |
| AXLES: | 24,000 FRONT/35,000 REAR |
| MODEL: | 54 FT. SQURT AERIAL DEVICE |
| WATER/FOAM: | 750/25 GALLONS |
| PUMP: | WATEROUS CSU 2000 GPM |

COMPARTMENT DIMENSIONS-PRELIMINARY

| I.D. | FRAME OPENING | INTERIOR DIMENSIONS |
|------|-----------------|--|
| L1 | 40.50W x 66.25H | 42.25W x 69.50H x 12.50D <small>12.50D UPPER 24.50D LOWER</small> |
| L2 | 72.00W x 34.50H | 75.75W x 37.75H x 12.50D |
| L3 | 40.50W x 66.25H | 42.25W x 69.50H x 12.50D <small>12.50D UPPER 24.50D LOWER</small> |
| R1 | 40.50W x 28.25H | 42.25W x 31.75H x 24.50D |
| R2 | 40.50W x 28.25H | 42.25W x 31.75H x 24.50D |

GROUND LADDERS:
 ONE DUO-SAFETY 900A 24 FT. 2-SECTION
 ONE DUO-SAFETY 775A 14 FT. ROOF
 ONE DUO-SAFETY 585A 10 FT. FOLDING
 TWO CUSTOMER SUPPLIED PIKE POLES

CUSTOMER

THIS DRAWING IS A CLOSE APPROXIMATION OF YOUR FIRE APPARATUS. IN ALL CASES WHERE THE DRAWING AND THE WRITTEN SPECIFICATION DIFFER, THE SPECIFICATION SHALL PREVAIL. PLEASE WORK WITH YOUR DEALER TO ASSURE THAT THE WRITTEN SPECIFICATION REPRESENTS WHAT YOU WANT IN YOUR FINISHED PRODUCT. SPARTAN EMERGENCY RESPONSE BUILDS TO THE WRITTEN SPECIFICATION, NOT THE DRAWING TO ASSURE THAT YOUR NEEDS ARE MET.

PROPRIETARY AND CONFIDENTIAL

THE INFORMATION CONTAINED IN THIS DRAWING IS THE SOLE PROPERTY OF SPARTAN EMERGENCY RESPONSE. ANY REPRODUCTION IN PART OR AS A WHOLE WITHOUT THE WRITTEN PERMISSION OF SPARTAN EMERGENCY RESPONSE IS PROHIBITED. SPARTAN MOTORS USA, INC. D/B/A SPARTAN EMERGENCY RESPONSE.

HOSE BED CONFIGURATION-LEFT TO RIGHT:
 300 FEET OF 1-3/4" HOSE
 300 FEET OF 2-1/2" HOSE
 1200 FEET OF 4" SUPPLY HOSE

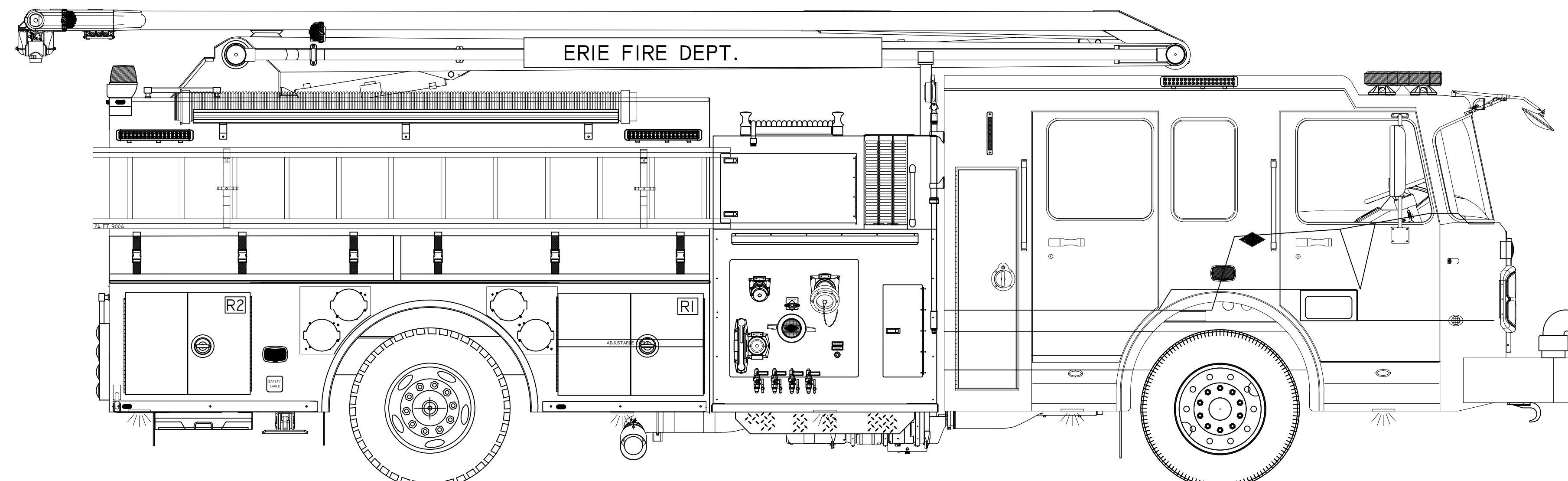
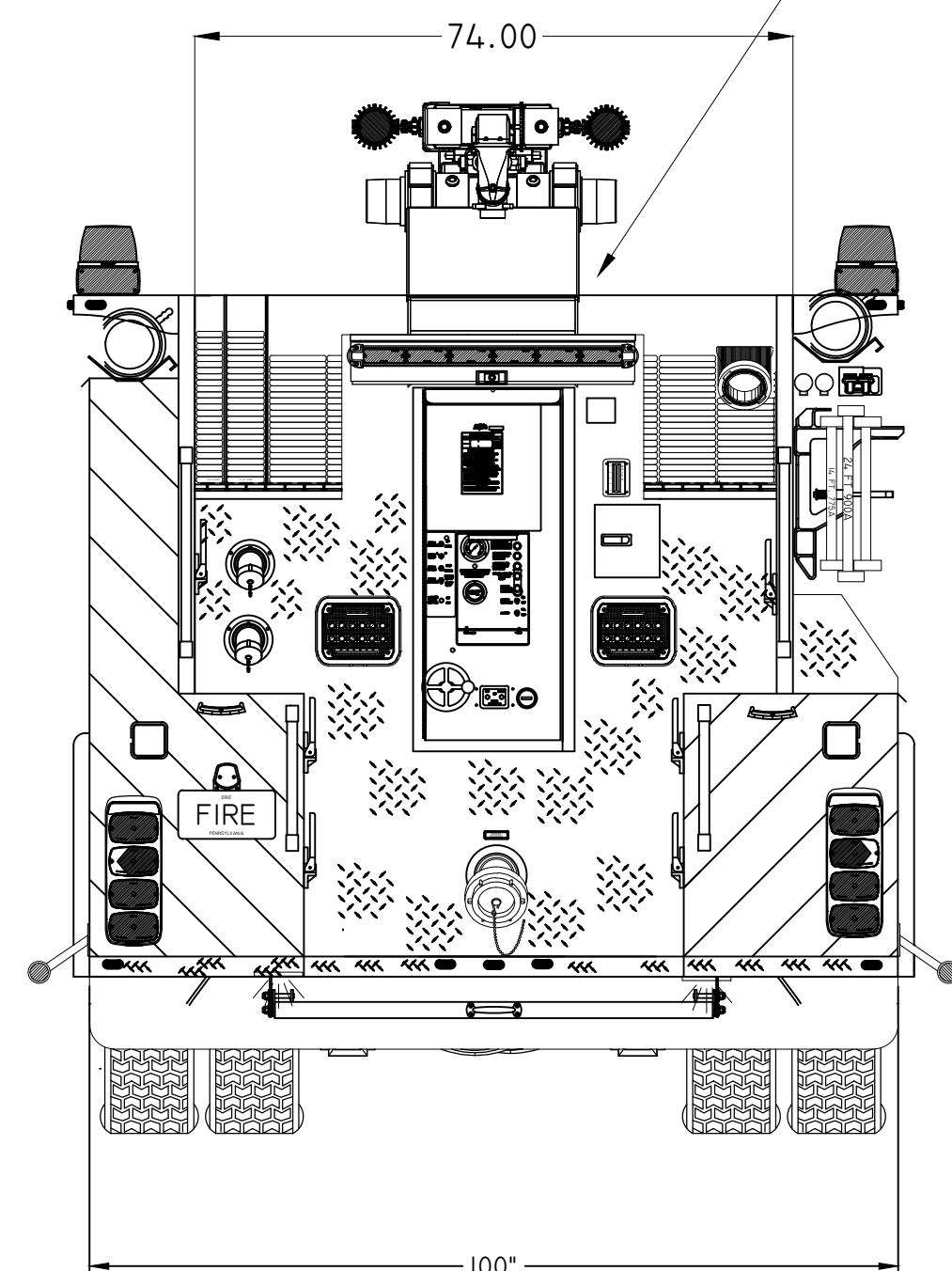

| REV | DATE | DESCRIPTION | NAME |
|-----|---------|-------------------|------|
| 1 | 2/18/24 | SECOND BID REVIEW | WWB |
| 0 | 1/7/24 | INITIAL DRAWING | WWB |

SCALE: NOT TO SCALE

ERIE FIRE DEPARTMENT
 ERIE, PENNSYLVANIA

 TRUCK NUMBER: DRAWING
 3-053-0086